



100L AUTOCLAVE FRONT LOADING

EH100-BASE
SH100-BASE



150L AUTOCLAVE FRONT LOADING

EH150-BASE
SH150-BASE



200L AUTOCLAVE FRONT LOADING

EH200-BASE
SH200-BASE

Priorclave's Base range covers "the basics": media preparation, waste loads, and sterilising loose instruments, open containers, and labware. These are high-efficiency cylindrical chambered autoclaves, caster-mounted for easy transport. They are well suited to research, quality assurance, and teaching labs. Easy maintenance and light resource consumption help ensure a low lifetime cost of ownership. All Base models include fully programmable cycle customisation, "media warming," integrated cooling and freesteaming systems, and drain protection.

KEY FEATURES

- Quickseal single-action door fitted with thermal and pressure locks to prevent opening at load temperature above 80°C and pressures above 0.2 bar.
- Tactrol® 3 microprocessor control with simple and fully variable setting of process time, temperature with graphic indication of cycle status.
- Automatic timed free-steaming.
- Low water level sensor.
- Two full width stainless steel load shelves.
- Epoxy coated panels and frame members are treated with an anti-bacterial agent which is effective against all bacteria and fungi including MRSA.
- Pressure vessel carries a 10 year warranty and is insurance approved.
- Service and support direct from manufacturer (or appointed distributor).

SPEAK WITH AN AUTOCLAVE EXPERT



+44 (0)20 8316 6620 • priorclave.co.uk • sales@priorclave.co.uk

Our highly trained service technicians provide dedicated pre- and after-sales support including planned maintenance programmes to ensure you get the most from your Priorclave.

100L AUTOCLAVE FRONT LOADING

EH100-BASE, SH100-BASE

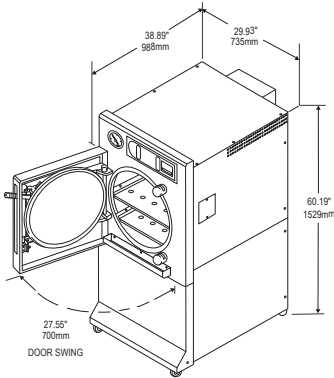

Heat Input	Chamber Volume	Operating Range	Loading Format	Loading Height	Heating Power
Internal Electrical or Direct Steam Source	100 Liters	Up to 138 °C, 2.4 Bar (280 °F 34 psi)	Front Loading	860mm (33.9")	7kW at 30A; 7kW at 15A
Chamber Dimensions diameter x depth		Bottom Shelf Dimensions w x d		Top Shelf Dimensions w x d	
500 x 535mm (19.5" x 21.1")		375mm x 535mm (14.76" x 21.06")		485mm x 535mm (19.09" x 21.06")	
Outside Dimensions w x d x h	Weight (unloaded)	Minimum Installation	Door Swing		
735 x 988 x 1529mm (29.93" x 38.89" x 60.19")	190Kg (429.9 lbs)	Please allow 500mm (19.69") either side and 300mm (11.81") at the back of the Autoclave.	700mm (27.55")		

150L AUTOCLAVE FRONT LOADING

EH150-BASE, SH150-BASE

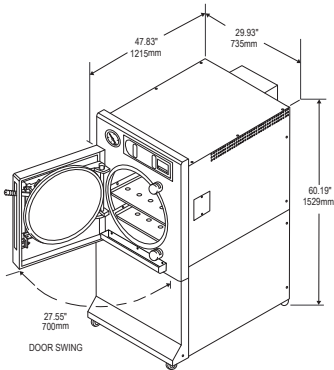

Heat Input	Chamber Volume	Operating Range	Loading Format	Loading Height	Heating Power
Internal Electrical or Direct Steam Source	150 Liters	Up to 138 °C, 2.4 Bar (280 °F 34 psi)	Front Loading	860mm (33.9")	7kW at 30A; 10.5kW at 15A
Chamber Dimensions diameter x depth		Bottom Shelf Dimensions w x d		Top Shelf Dimensions w x d	
500 x 740mm (X")		375 x 740mm (14.76" x 29.13")		485 x 740mm (19.09" x 29.13")	
Outside Dimensions w x d x h	Weight (unloaded)	Minimum Installation	Door Swing		
735 x 1215 x 1529mm (29.93" x 47.83" x 60.19")	208Kg (458.6 lbs)	Please allow 500mm (19.69") either side and 300mm (11.81") at the back of the Autoclave.	700mm (27.55")		

200L AUTOCLAVE FRONT LOADING

EH200-BASE, SH200-BASE

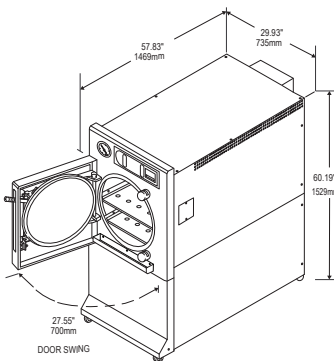

Heat Input	Chamber Volume	Operating Range	Loading Format	Loading Height	Heating Power
Internal Electrical or Direct Steam Source	200 litres	Up to 138 °C, 2.4 Bar (280 °F 34 psi)	Front Loading	860mm (33.9")	7kW at 30A; 10.5kW at 15A
Chamber Dimensions diameter x depth		Bottom Shelf Dimensions w x d		Top Shelf Dimensions w x d	
500 x 1025mm (19.68" x 40.35")		375 x 1025mm (14.76" x 40.35")		485 x 1025mm (19.09" x 40.35")	
Outside Dimensions w x d x h	Weight (unloaded)	Minimum Installation w x d x h	Door Swing		
735 x 1469 x 1529mm (29.93" x 57.83" x 60.19")	236kg (520.29 lbs)	Please allow 500mm (19.69") either side and 300mm (11.81") at the back of the Autoclave.	700mm (27.55")		

CONFORMITY & COMPLIANCE

UK Standard	ISO 9001 / CE Marked / BS2646	INT Standard	EMC Compliance
US Standard	ASME	Sustainability	ACT Label Issued
EU Standard	CE / ISO 9001 / PED 97/23/EC	Service	Priorclave Trained Standard