



40L AUTOCLAVE BENCHTOP

B40-SMART



60L AUTOCLAVE BENCHTOP

B60-SMART

Priorclave's Smart benchtop autoclaves are intended for industrial, research, and production labs and facilities with greater or more diverse needs. They adeptly handle standard tasks (e.g., media prep, waste loads, labware) but can also produce drier loads and more reliably handle complex loads that tend to trap air. Ideal for mixed waste, biological waste, pathogen-heavy materials, cloth and textile sterilisation, soil and substrate preparation, wrapped instruments, and porous loads. These sterilisers feature fully customisable cycles (with expanded memory), pre-cycle and post-cycle vacuum, integrated cooling and freesteaming, and air intake filtration.

SPEAK WITH AN AUTOCLAVE EXPERT



+44 (0)20 8316 6620 • priorclave.co.uk • sales@priorclave.co.uk

Our highly trained service technicians provide dedicated pre- and after-sales support including planned maintenance programmes to ensure you get the most from your Priorclave.

KEY FEATURES

- Quickseal single-action door fitted with thermal and pressure locks to prevent opening at load temperature above 80°C and pressures above 0.2 bar.
- Tactrol® 3 microprocessor control with simple and fully variable setting of process time, temperature with graphic indication of cycle status.
- Automatic timed free-steaming.
- Forced Air Cooling.
- Pre-cycle vacuum in which multiple Vacuum stages are programmed with interspersed heating to achieve steam penetration.
- Pulsed freesteaming to maximise efficiency of Pre-cycle vacuum phase.
- Media Warming and Delayed Start functions keep autoclaved media at a usable temperature ready for immediate use.
- Vacuum Assisted Cooling.
- Low water level sensor.
- Two loading shelves.
- Epoxy coated panels and frame members are treated with an anti-bacterial agent which is effective against all bacteria and fungi including MRSA.
- Pressure vessel carries a 10 year warranty and is insurance approved.
- Service and support direct from manufacturer (or appointed distributor).

40L AUTOCLAVE BENCHTOP

B40-SMART

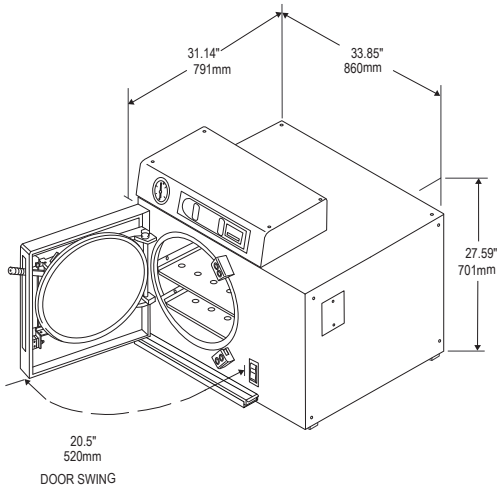

Heat Input	Chamber Volume	Operating Range	Loading Format	Loading Height	Heating Power
Electrical	40 Liters	Up to 138 °C, 2.4 Bar (280 °F 34 psi)	Front Loading	Benchtop/ Counter Level	3kW - 13A single phase
Chamber Dimensions diameter x depth		Bottom Shelf Dimensions w x d		Top Shelf Dimensions w x d	
350 x 420mm (13.8" x 16.5")		245 x 420mm (9.64" x 16.53")		245 x 420mm (9.64" x 16.53")	
Outside Dimensions w x d x h		Weight (unloaded)	Minimum Installation	Door Swing	
860 x 791 x 701mm (33.85" x 31.14" x 27.59")		92Kg (202.82 lbs)	Please allow 500mm (19.69") either side and 300mm (11.81") at the back of the Autoclave.	520mm (20.5")	

60L AUTOCLAVE BENCHTOP

B60-SMART

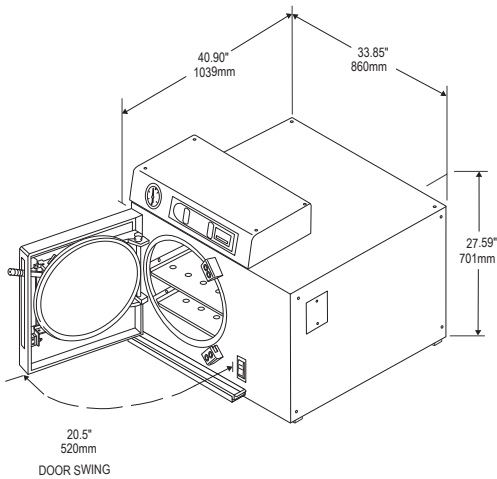

Heat Input	Chamber Volume	Operating Range	Loading Format	Loading Height	Heating Power
Electrical	60 Liters	Up to 138 °C, 2.4 Bar (280 °F 34 psi)	Front Loading	Benchtop/ Counter Level	3.2kW - 13A (Single Phase)
Chamber Dimensions diameter x depth		Bottom Shelf Dimensions w x d		Top Shelf Dimensions w x d	
350mm x 625mm (13.8" x 24.4")		245 x 678mm (9.64" x 26.69")		330 x 678mm (12.99" x 26.69")	
Outside Dimensions w x d x h		Weight (unloaded)	Minimum Installation	Door Swing	
860 x 1039 x 701mm (33.85" x 40.90" x 27.59")		90Kg (198.41 lbs)	Please allow 500mm (19.69") either side and 300mm (11.81") at the back of the Autoclave.	520mm (20.5")	

CONFORMITY & COMPLIANCE

UK Standard	ISO 9001 / CE Marked / BS2646
US Standard	ASME
EU Standard	CE / ISO 9001 / PED 97/23/EC

INT Standard	EMC Compliance
Sustainability	
Service	Priorclave Trained Standard