



## 40L AUTOCLAVE BENCHTOP

B40-BASE



## 60L AUTOCLAVE BENCHTOP

B60-BASE

Priorclave's Base range covers "the basics": media preparation, waste loads, and sterilising loose instruments, open containers, and labware. These high-efficiency cylindrical-chamber front-loading tabletop autoclaves are well suited to smaller research, quality assurance, and teaching labs. Easy maintenance and light resource consumption help ensure a low lifetime cost of ownership. Base Benchtop models enjoy the same robust design, custom build, and quality components as our other models and ranges. Base models include fully programmable cycle customisation, "media warming," integrated cooling and freesteaming systems, and drain protection.

## SPEAK WITH AN AUTOCLAVE EXPERT



+44 (0)20 8316 6620 • [priorclave.co.uk](http://priorclave.co.uk) • [sales@priorclave.co.uk](mailto:sales@priorclave.co.uk)

Our highly trained service technicians provide dedicated pre- and after-sales support including planned maintenance programmes to ensure you get the most from your Priorclave.

## KEY FEATURES

- Quickseal single-action door fitted with thermal and pressure locks to prevent opening at load temperature above 80°C and pressures above 0.2 bar.
- Tactrol® 3 microprocessor control with simple and fully variable setting of process time, temperature with graphic indication of cycle status.
- Automatic timed free-steaming.
- Forced Air Cooling.
- Media Warming and Delayed Start functions keep autoclaved media at a usable temperature ready for immediate use.
- Low water level sensor.
- Two loading shelves.
- Epoxy coated panels and frame members are treated with an anti-bacterial agent which is effective against all bacteria and fungi including MRSA.
- Pressure vessel carries a 10 year warranty and is insurance approved.
- Service and support direct from manufacturer (or appointed distributor).

# 40L AUTOCLAVE BENCHTOP

B40-BASE

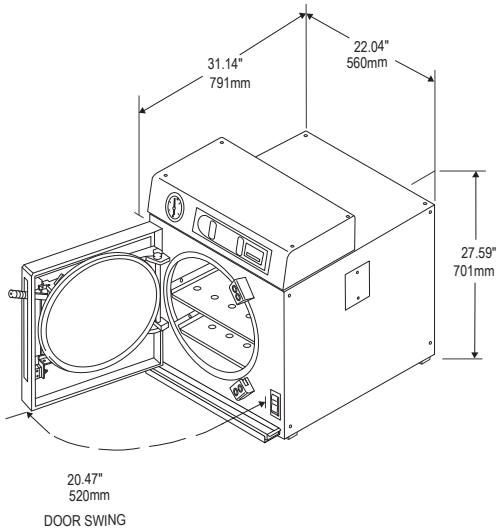

Heat Input	Chamber Volume	Operating Range	Loading Format	Loading Height	Heating Power
Electrical	40 Liters	Up to 138 °C, 2.4 Bar (280 °F 34 psi)	Front Loading	Benchtop/ Counter Level	3kW - 13A single phase
Chamber Dimensions diameter x depth		Bottom Shelf Dimensions w x d		Top Shelf Dimensions w x d	
350 x 420mm (13.8" x 16.5")		245 x 420mm (9.64" x 16.53")		330 x 420mm (12.99" x 16.53")	
Outside Dimensions w x d x h		Weight (unloaded)	Minimum Installation	Door Swing	
560 x 791 x 701mm (22.04" x 31.14" x 27.59")		70Kg (154.3 lbs)	Please allow 500mm (19.69") either side and 300mm (11.81") at the back of the Autoclave.	520mm (20.47")	

# 60L AUTOCLAVE BENCHTOP

B60-BASE

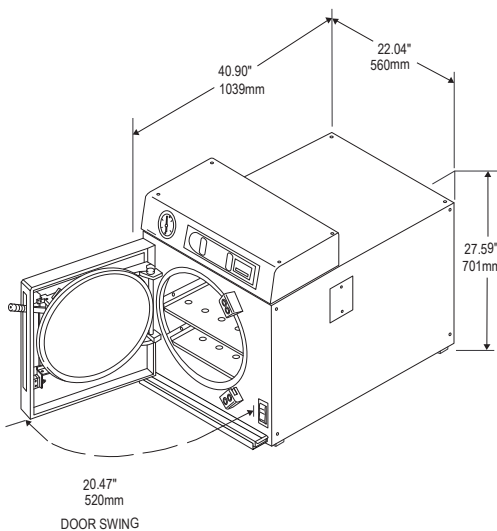

Heat Input	Chamber Volume	Operating Range	Loading Format	Loading Height	Heating Power
Electrical	60 Liters	Up to 138 °C, 2.4 Bar (280 °F 34 psi)	Front Loading	Benchtop/ Counter Level	3kW - 13A single phase
Chamber Dimensions diameter x depth		Bottom Shelf Dimensions w x d		Top Shelf Dimensions w x d	
350 x 625mm (13.8" x 24.4")		245 x 678mm (9.64" x 26.69")		330 x 678mm (12.99" x 26.69")	
Outside Dimensions w x d x h		Weight (unloaded)	Minimum Installation	Door Swing	
560 x 1039 x 701mm (22.04" x 40.90" x 27.59")		85Kg (187 lbs)	Please allow 500mm (19.69") either side and 300mm (11.81") at the back of the Autoclave.	520mm (20.47")	

## CONFORMITY & COMPLIANCE

UK Standard ISO 9001 / CE Marked / BS2646

US Standard ASME

EU Standard CE / ISO 9001 / PED 97/23/EC

INT Standard

EMC Compliance

Sustainability

Service

Priorclave Trained Standard